

ATAC FLASHAR



CONTINUOUS FLASH POINT ANALYSER

The ATAC Flashar is a completely automatic process stream analyser for the determination of flash point. The analysis can be performed to correlate with either the ASTM D93 or D56 standard test.

- Correlates to ASTM D93 or D56 test methods
- Exceeds test method repeatability
- Accurate, reliable catalytic sensor technology
- Fast continuous flash point analysis enables process optimisation

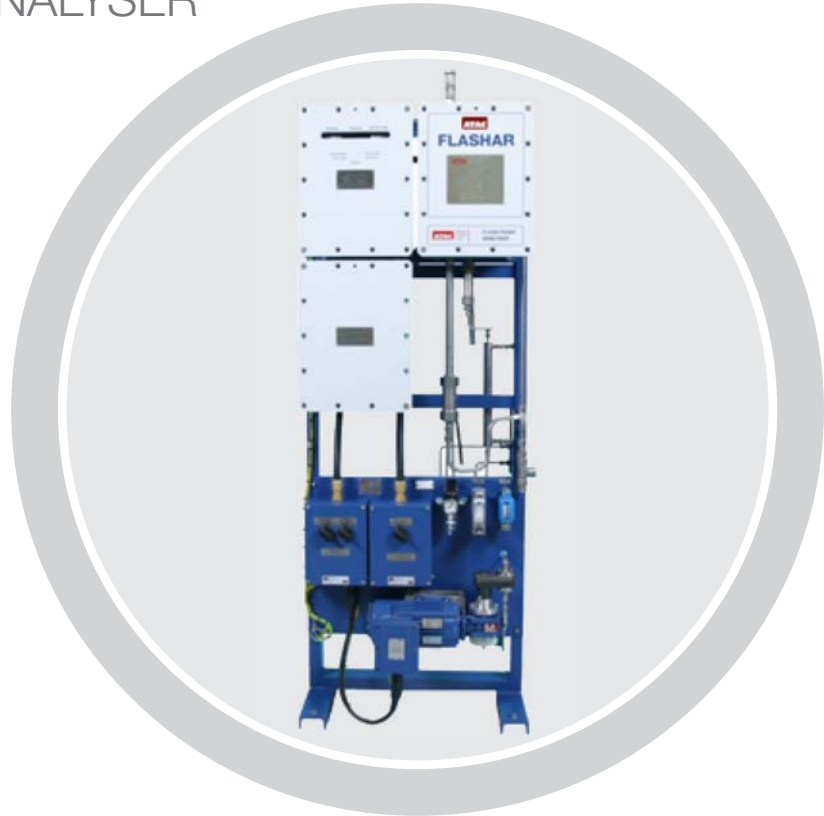

TYPICAL APPLICATIONS

The ATAC Flashar is ideal for monitoring processing units to control cut points or quality of blending components and finished products to meet quality specifications.

- Pipeline monitoring
- Heavy gas oil & fuel oil
- Lube oil

PRINCIPLE OF OPERATION

The flash point of a liquid hydrocarbon is the lowest temperature at which it will vaporise to form an ignitable mixture in air. Its measurement therefore requires an ignition source; in the standard laboratory tests this is a flame.

The ATAC Flashar measures flashpoint continuously, using a catalytic sensor instead of the test flame specified in the laboratory test. This catalytic sensor consists of a thermocouple surrounded by a platinum/ palladium catalyst. When heated, it becomes active and acts as an LEL sensor, giving a constant millivolt output at the LEL value (which corresponds to the flash point). Flashar uses this output to control the temperature of the sample flowing through it such that the output remains constant at the LEL level. If the sample temperature is below the flash point, the output drops and the sample is heated until the set point is regained. If the output rises above the set point, the sample is allowed to cool until the set point is regained. This continual heating and cooling maintains the sample at its flash point. The sample temperature is measured and converted to a 4-20mA output representing the flash point.

Flashar uses this catalytic detection method to measure flash point because the catalyst lowers the temperature at which oxidation of the hydrocarbon vapour occurs. By reacting at a lower temperature than either a test flame or sparking electrical contacts, the carbonisation of product is virtually eliminated and "coking" problems vastly reduced. The catalyst reduces the oxidation temperature because of absorption of the hydrocarbon molecules on the catalyst surface. Their chemical bonds are weakened and they become more reactive to oxygen.

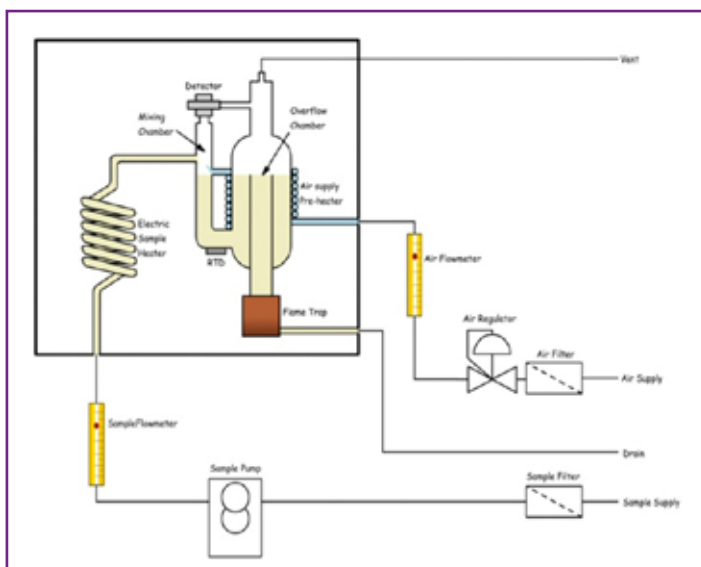

Figure 1: Flashar schematic

The Flashar analyser schematic is shown in Figure 1. Clean, fresh sample enters the main heater at a flow rate determined by the integral sample pump. It enters the mixing chamber where it is mixed with air preheated by the hot sample, excess sample passing to the overflow chamber and then to drain via the flame trap.

The resulting vapour/air mixture passes through the heated detector housing where the vapour concentration is detected by the catalytic oxidation of the vapour. It is then vented. The detector is in the vapour/air stream above the mixing chamber and produces a variable voltage output which depends on the catalyst temperature and, therefore, the vapour concentration. This voltage is compared with the set point temperature value and an output produced which is proportional to the input error.

This output controls the ON/OFF ratio of the main heater's electrical supply and, therefore, the incoming sample temperature. If the output is low compared to the set point the incoming sample temperature is raised. If the output is high the reverse is true. When the output is identical to the set point, the heater controls the incoming sample temperature, producing a vapour concentration corresponding to the critical flash point concentration. The flash point temperature is measured by a platinum resistance thermometer attached to the liquid section of the mixing chamber. An amplifier converts this signal to a standard 4-20mA output.

The Flashar performs exactly the same function as the standard ASTM/IP laboratory tests but provides on-line sample checking automatically on a continuous basis, identifying changes in product flash point as they occur. The analyser is built with solid state circuitry and has no moving parts or sparking contacts. It is extremely reliable and is designed for easy on-line checking, with the facility for introducing test samples. The Flashar is supplied complete with flow control systems for sample and air.

SPECIFICATIONS

| | | | |
|-------------------------------------|---|--|----------------------------------|
| Range | 25°C to 175°C - upper range limit is dependent upon sample composition | | |
| Span | 50°C minimum | | |
| Repeatability | ±1°C | | |
| Response time | 3 minutes approximately | | |
| Dead time | 1 minute approximately | | |
| Output signal | Range: 4-20mA fully isolated Load impedance: 700 ohms maximum connected load Alarm and status contacts: volt free contacts rated 0.5 amps 250V ac are provided for: <ul style="list-style-type: none"> • high sample temperature • stand-by • power failure/ off line | | |
| Local display | LED displays provide status information. Output signal is displayed on an analogue meter. | | |
| Sample conditions required at inlet | Pressure: | 3 to 7 barg (optional integral pump available) | |
| | Temperature: | ≥10°C below expected flash point | |
| | Flow: | 2 litres/hour free of water and entrained solids | |
| | H ₂ S content: | 2% maximum | |
| Sample conditioning | Complete systems can be supplied to pre-condition process sample to the conditions required at the analyser inlet. | | |
| Sample disposal | Sample outlet drain must be connected to a system which is at atmospheric pressure. Sample recovery systems are available. | | |
| Analyser vent | Analyser must be vented to atmosphere. | | |
| Power supply | Voltage 115V or 230V ac ±10% | Frequency 50 or 60Hz | |
| Air supply | Pressure: | 3 to 7 barg clean, dry instrument air | |
| | Consumption: | 50 litres/hour | |
| Environmental protection | Flashar is weatherproof to IP55 and will operate in ambient temperatures within the range +5°C to +55°C. However, a weatherproof shelter is strongly recommended. | | |
| Certification | ATEX certified Ⓢ II 2G EEx d IIB T3 or T4 (T _{amb} +55) for use in zone 1 hazardous areas. Certificate no. DEMKO 03 ATEX 135888 | | |
| Weight & dimensions connections | 160kg (approximately): | 640mm (w) x 330mm (d) x 1730mm (h) | |
| | Sample inlet: | ¼" NPT (female) | Sample to drain: ½" NPT (female) |
| | Analyser vent: | ½" NPT (female) | Air inlet: ¼" NPT (female) |
| | Water inlet: | ¼" NPT (female) | Water outlet: ¼" NPT (female) |
| | Flash unit vent: | ½" NPT (female) | Power and signals: |



ANAEL - Analyse en ligne

ZI - 15 rue Nobel
45700 VILLEMAMDEUR - FRANCE

Tel : +33 2 38 85 77 12

info@analyse-en-ligne.com

Fax : +33 2 38 85 99 65

www.analyse-en-ligne.com