

PHARMA REFRACTOMETER FOR IN-LINE CONCENTRATION MEASUREMENT

K-PATENTS
PROCESS INSTRUMENTS



K-PATENTS PHARMA REFRACTOMETER PR-23-AC



ANAEL SAS
15 rue Nobel - 45700 VILLEMANDEUR - FRANCE
Tel : +33 2 38 85 77 12 Email : info@analyse-en-ligne.com

SB:PR-23/Pharma

TYPICAL APPLICATIONS

PHARMACEUTICAL CHEMICALS

Acetylsalicylic acid, Calcium gluconate, Glycerophosphates, Chloral hydrate, Saccharin, Antihistamines, Tranquilizers, Antifilarials, Diethyl carbamazine citrate, Antidiabetics and more.

ACTIVE PHARMACEUTICAL INGREDIENTS

Actives, Excipients, Intermediates, Raw material, Fine chemicals, and Bulk chemicals.

ANTIBIOTICS

Penicillin, Streptomycin, Tetracyclines, Chloramphenicol, and Antifungals.

BLOOD PRODUCTS

Blood, Plasma, Serum, Infusion liquids, Sodium chloride, and Glucose.

PROTEINS

Proteins and Protein buffer solutions

SYNTHETIC DRUGS

Sulfa drugs, Antituberculosis drugs, Antileprotic drugs, Analgesics, Anesthetics, and Antimalarials.

VITAMINS

Ascorbid acid, Ca-arabonate, Riboflavin, Vitamin-B, Vitamin-C Sodium Pantonate. and more.

SYNTHETIC HORMONES

SYRUPS

Concentrated aqueous solutions of sucrose.

DRUGS OF VEGETABLE ORIGIN

Quinine, Strychnine and Brucine, Emetine, and Digitalis Glycosides, and Herbal extracts.

VACCINES AND SERA

SURGICAL SUTURES

Glue for human tissue.

ACIDS, BASES AND SOLVENTS



K-PATENTS PHARMA REFRACTOMETER PR-23-AC



ANAEL SAS

15 rue Nobel - 45700 VILLEMANDEUR - FRANCE

Tel : +33 2 38 85 77 12

Email : info@analyse-en-ligne.com

REGULATORY COMPLIANCE

Food and Drug Administration's (FDA's) regulations require documented act of demonstrating that a specific procedure, process, and activity will consistently lead to the expected results. This is called validation.

K-Patents Process Refractometer PR-23 is ideal real-time instrument that meets the pharmaceutical industry standards and guidelines including PAT, GMP, CIP/SIP, 21 CFR Part 11 and validation. The ability to understand and continuously control parameters such as Refractive Index n_D contributes significantly to the development of effective drugs and efficient manufacturing processes.

K-Patents Pharma Refractometer PR-23-AC fulfills the pharmaceutical drug production regulations for process wetted part materials, sealing, and surface roughnesses. No animal originated media are used in the machining and polishing processes.

K-Patents refractometers are designed, manufactured and serviced under ISO 9001 quality system and procedures that guarantee the accuracy and repeatability of the measurement results. Each sensor is provided with a calibration certificate comparing a set of standard liquids to the actual sensor output. Therefore, the calibration and accuracy can be routinely verified with the traceable standard refractive index liquids.

Validation often includes the qualification of systems and equipment. It is a requirement for Good Manufacturing Practices (GMPs) and other regulatory requirements.

K-Patents provides a qualification procedure and equipment that help the user to prove the suitability of the refractometer for its designated function. This includes a set up for tests with refractometer in a laboratory or in a pilot process in making small quantities of the drug.

EQUIPMENT QUALIFICATION

These steps are common for a K-Patents Pharma Refractometer PR-23-AC qualification process:

1A. LAB TEST WITH STATIC SAMPLE

Laboratory test for manual sampling in a laboratory cuvette consisting of an agitator with stirrer and connections for thermostat controlled water.

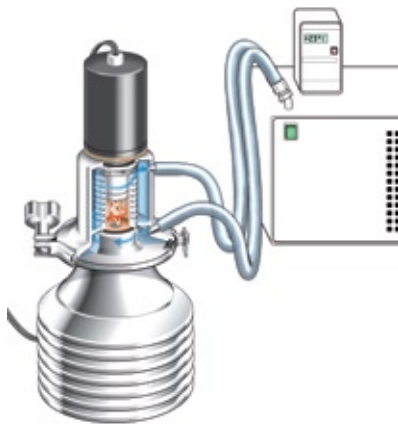

2. TEST IN PILOT SCALE

Installation in a pilot process using a pharma mini flow cell.



3. INSTALLATION AT FULL PRODUCTION SCALE

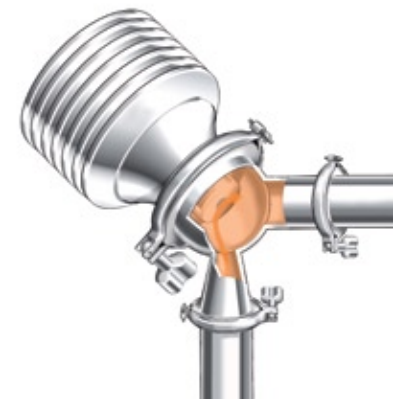

1B. LAB TEST WITH CONTINUOUS SAMPLE

Laboratory test for continuous sampling in a laboratory cuvette consisting of connections for a sample inlet and outlet and for thermostat controlled water.

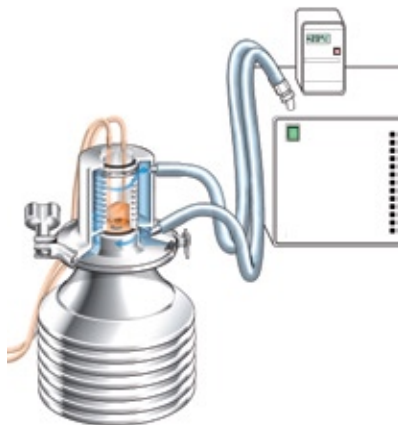

DRUG FORMULATION

Step one of the equipment qualification process is also an applicable procedure for creating proprietary chemical curves for different drug recipes on the user's own manufacturing facility. This makes the drug formulation and validation easier in considerably less time.

DIGITAL MEASUREMENT PRINCIPLE

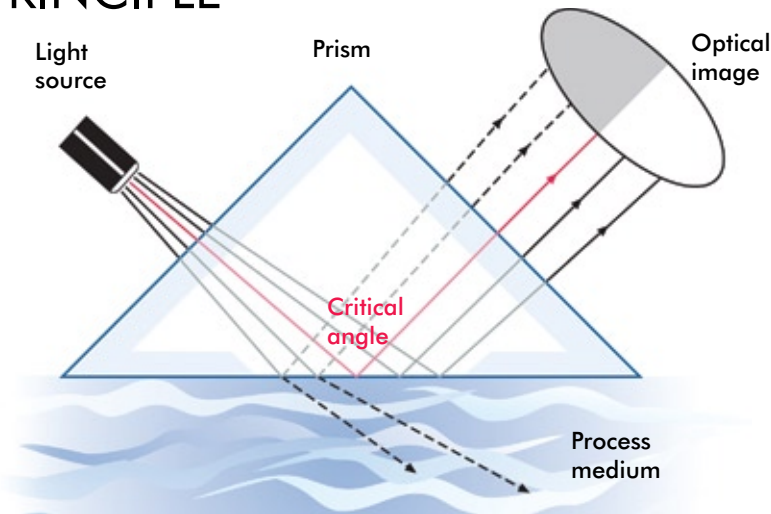

The light source sends light against the interface between a prism and the process solution, where the rays meet the surface at different angles.

The angle corresponding to the shadow line is called the Critical Angle of Total Reflection. The Critical Angle is a function of the refractive index and therefore the concentration of the solution.

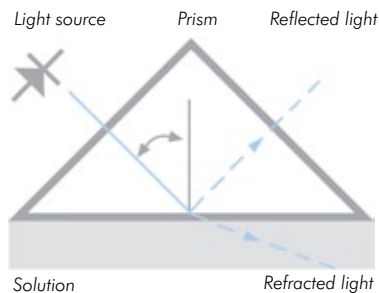

Depending on the angle, some rays are totally reflected. And, some rays are only partially reflected, most of the light is refracted into the process solution.

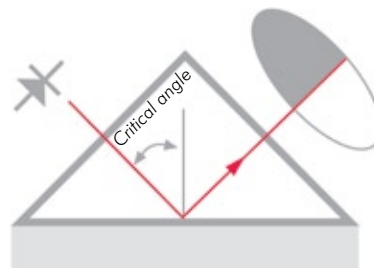

A digital CCD-camera detects the optical image and the shadow line. The camera transforms the optical image point-by-point to an electrical signal. The exact shadow line position is located and the refractive index n_D is determined.

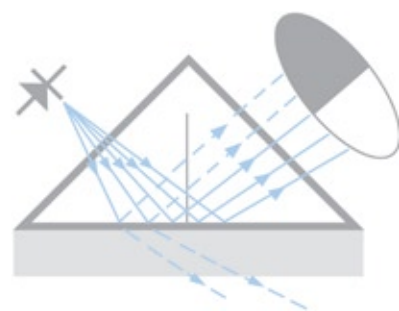

Thus an optical image with a dark sector and a light sector is created.

A built-in temperature sensor measures the temperature T on the interface of the process liquid. The indicating transmitter converts the refractive index n_D and temperature T to concentration units.

The diagnostics program ensures that the measurement is reliable.

FDA 21 CFR PART 11 ADHERENCE

The K-Patents Refractometer includes an Ethernet communication solution. Together with the user's own procedural and administrative user controls it facilitates electronic data records for FDA 21 CFR Part 11 adherence. The transmitter uses the UDP/IP protocol to communicate over the Ethernet to any type of computer. This eliminates human error and allows for refractometer generated measurement and diagnostic data capture for storage, analysis and reporting.

Any computer with a standard Ethernet connection can be configured to view and download data from the sensor by using a standard web browser.

Access to the refractometer and to the refractometer generated data can be restricted to authorized personnel only using a password protection.

DESIGN

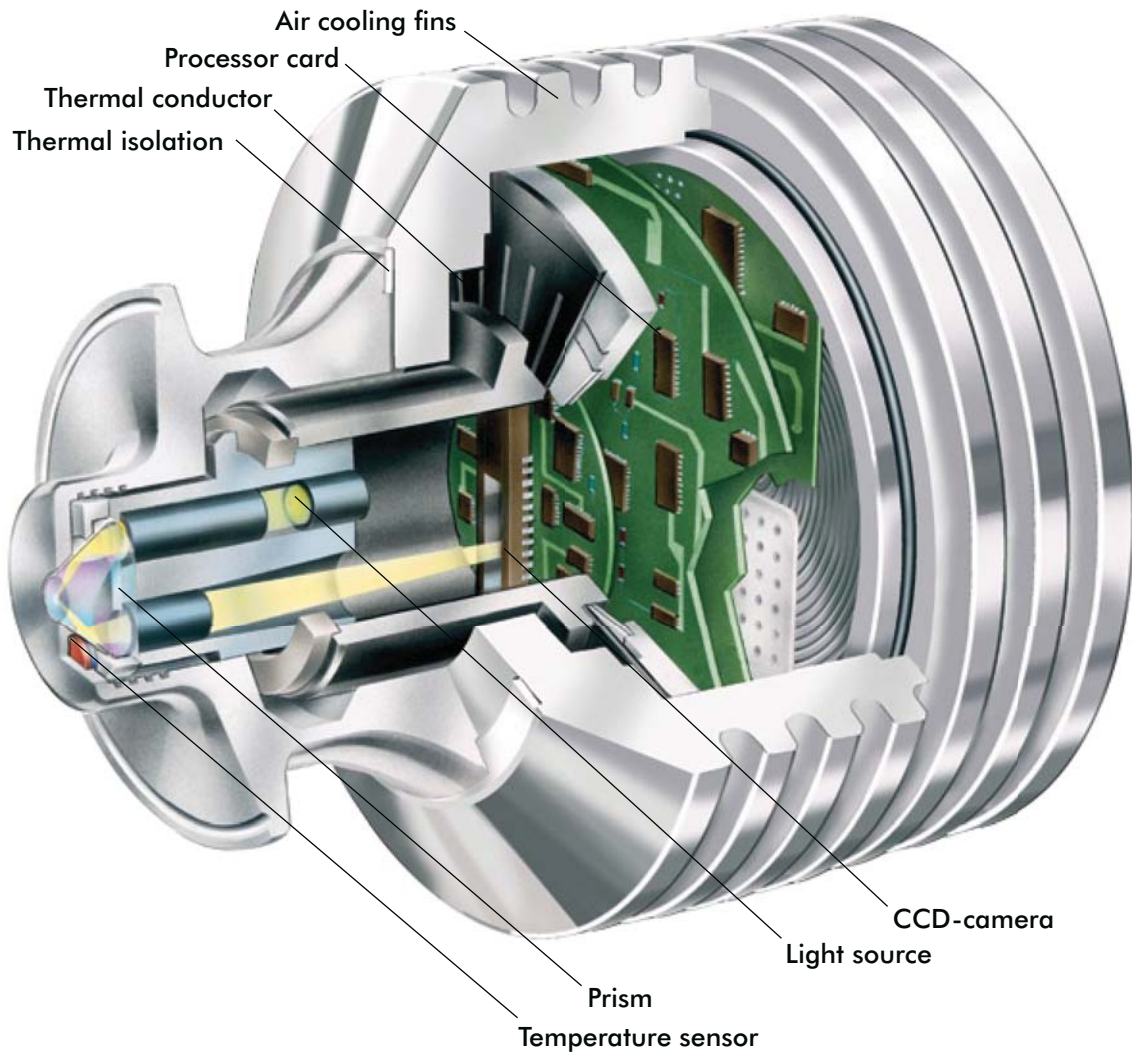

CORE-Optics

All measuring components (light source, prism, temperature sensor and CCD-camera) are in one solid CORE-optics module.

The patented CORE-optics is mechanically isolated from the influence of external forces and vibrations. The CORE-optics contains no mechanical adjustments.

(US Patent No. 6067151)

SPECIFICATIONS

Compact sensor PR-23-AC:

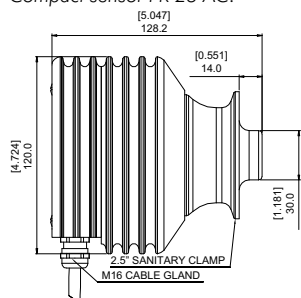

Laboratory test cuvette LTC for off-line laboratory testing:

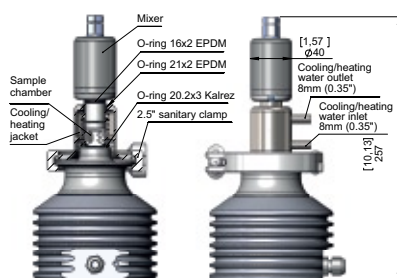

Mini flow cell PMFC for low volume pilot processes:

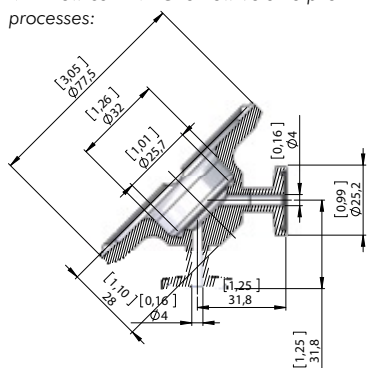

Indicating transmitter DTR in stainless steel enclosure:

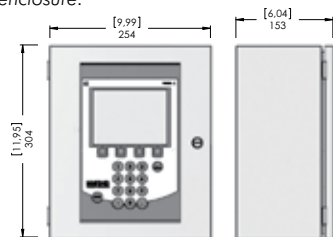

Refractive Index range:	Standard: Full range, $n_D = 1.3200...1.5300$ (corresponds to 0...100 % b.w.)
Accuracy:	Refractive index $n_D \pm 0.0002$ (corresponds typically to $\pm 0.1\%$ by weight) Repeatability $n_D \pm 0.0001$ (corresponds typically to $\pm 0.05\%$ by weight)
Speed of response:	1 s undamped, damping time selectable up to 5 min
Calibration:	With Cargille standard R.I. liquids over full range of $n_D 1.3200...1.5300$
CORE-Optics:	No mechanical adjustments (US Patent No. US6067151)
Digital measurement:	3648 pixel CCD element
Light source:	Light emitting diode (LED), 589 nm wavelength, sodium D-line
Temperature sensor:	Built-in Pt-1000, linearization according to IEC 751
Temperature compensation:	Automatic, digital compensation
Instrument verification:	According to ISO 9000 quality system: NIST traceable with standard R.I. liquids and Transmitter's menu guided procedure and report for printing
Ambient temperature:	Sensor: max. 45°C (113°F), min. -20°C (-4°F) Indicating transmitter: max. 50°C (122°F), min. 0°C (32°F)

SENSOR PR-23-AC:

Process connection:	Sanitary 3A-clamp 2.5"
Process temperature:	-20°C...130°C (-4°F...266°F)
Surface roughness, option:	Ra 0.4µm (15µ inch)
Process wetted parts, standard:	AISI 316L stainless steel, prism spinel, prism gaskets PTFE (teflon), EPDM
Sensor protection class:	IP67, Nema 4X
Sensor weight:	2 kg (4.4 lbs)
Laboratory test cuvette LTC for off-line laboratory testing:	AISI 316 L stainless steel laboratory test cuvette for manual and static sampling. Contains an agitator with PTFE (teflon) stirrer, and connections for sample inlet and outlet, and 1/4" tube connections for thermostat controlled water.

Pharma mini flow cell PMFC: For in-line testing of low volume samples in pilot conditions, process connection Sanitary 3A-clamp 1,5", electropolished wetted parts material with surface roughness of Ra 0.4µm (15µ inch)

INDICATING TRANSMITTER DTR:

Display:	320x240 pixel graphical LCD with LED backlight
Keypad:	18 membrane keys
Current output:	Two independent current outputs, 4-20 mA, max. load 1000 Ohm, galvanic isolation 1500 VDC or AC (peak), hold function during prism wash
Ethernet connection:	10/100 Mbit/s, data acquisition over UDP/IP Protocol with K-Patents data logging software
Power:	AC input 100-240 VAC/50-60 Hz, optional 24 VDC, 30 VA
Alarms/Wash relays:	Two built-in signal relays, max. 250 V/3 A
Sensor connectivity:	One or two sensors can be connected to the DTR. Sensors independent of each other: own parameter sets and usable in different applications. Two current outputs configurable independently to indicate process concentration or temperature of either sensor.

Transmitter protection class:	Enclosure IP66, Nema 4X
Enclosure material:	Standard: Polycarbonate, optional: AISI 304 stainless steel
Indicating transmitter weight:	4.5 kg (10 lbs)
INTERCONNECTING CABLE:	IEC 61158-2 compliant two-wire cable
Interconnecting cable length:	Standard 10 m (33 ft), max. 200 m (660 ft)

ORDERING INFORMATION:	- Sensor type and flow cell option(s)	- Process pipe size
	- Desired scale	- Process flow rate
	- Properties of process solution	- Supply voltage and frequency
	- Process temperature range	- Material certificates
	- Surface roughness	- Options



ANAEL - Analyse en ligne

ZI - 15 rue Nobel
45700 VILLEMANDEUR - FRANCE

Tel : +33 2 38 85 77 12
info@analyse-en-ligne.com

Fax : +33 2 38 85 99 65
www.analyse-en-ligne.com